

DH1~DH2=16171±20

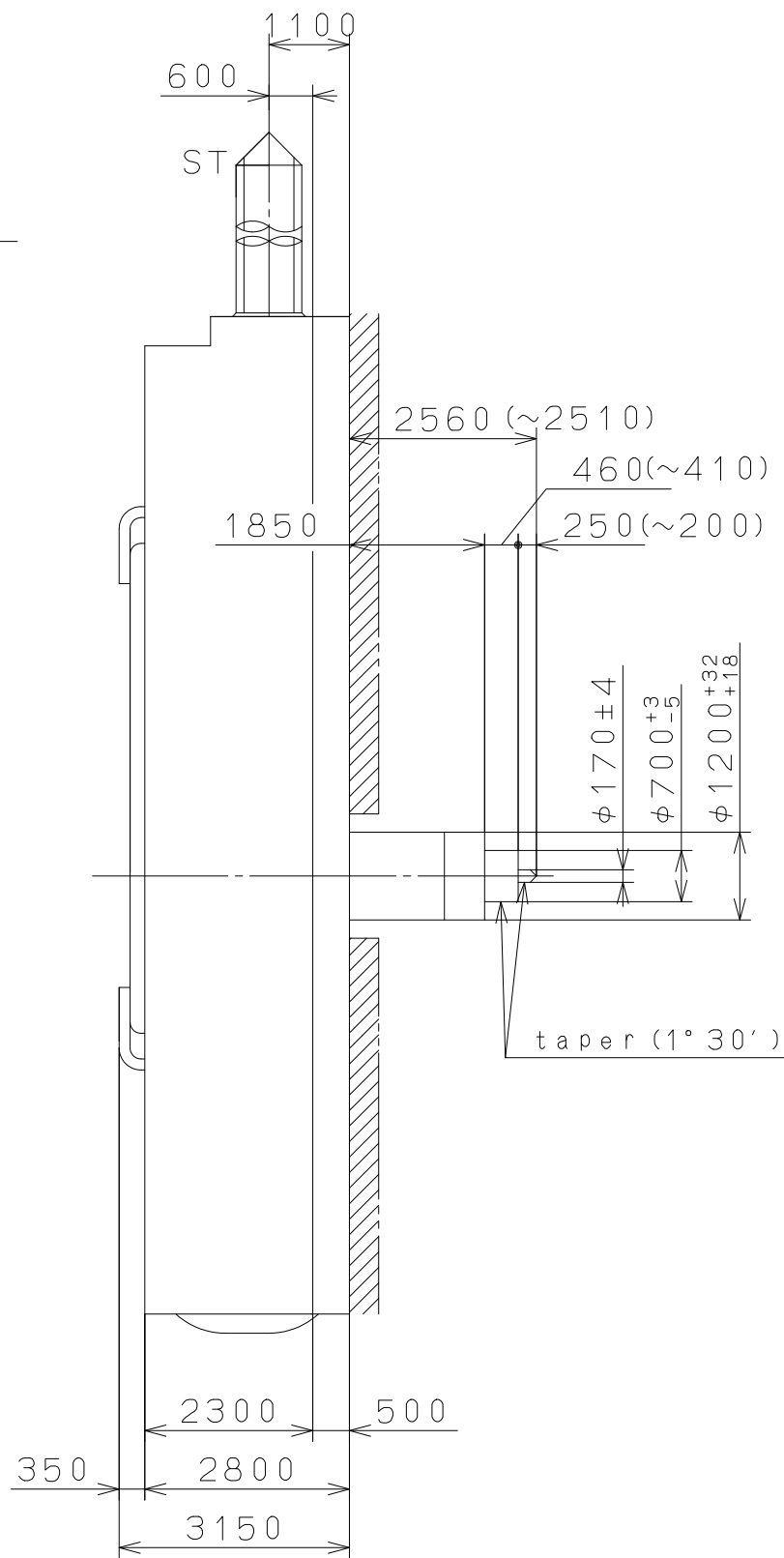

Coordinates

Mark	X	Y	R
GM	0	0	—
a1	-7838	-4250	500
a2	-6550	-4855	300
a3	-5951	-4888	300
a4	6101	-4790	300
a5	6700	-4756	300

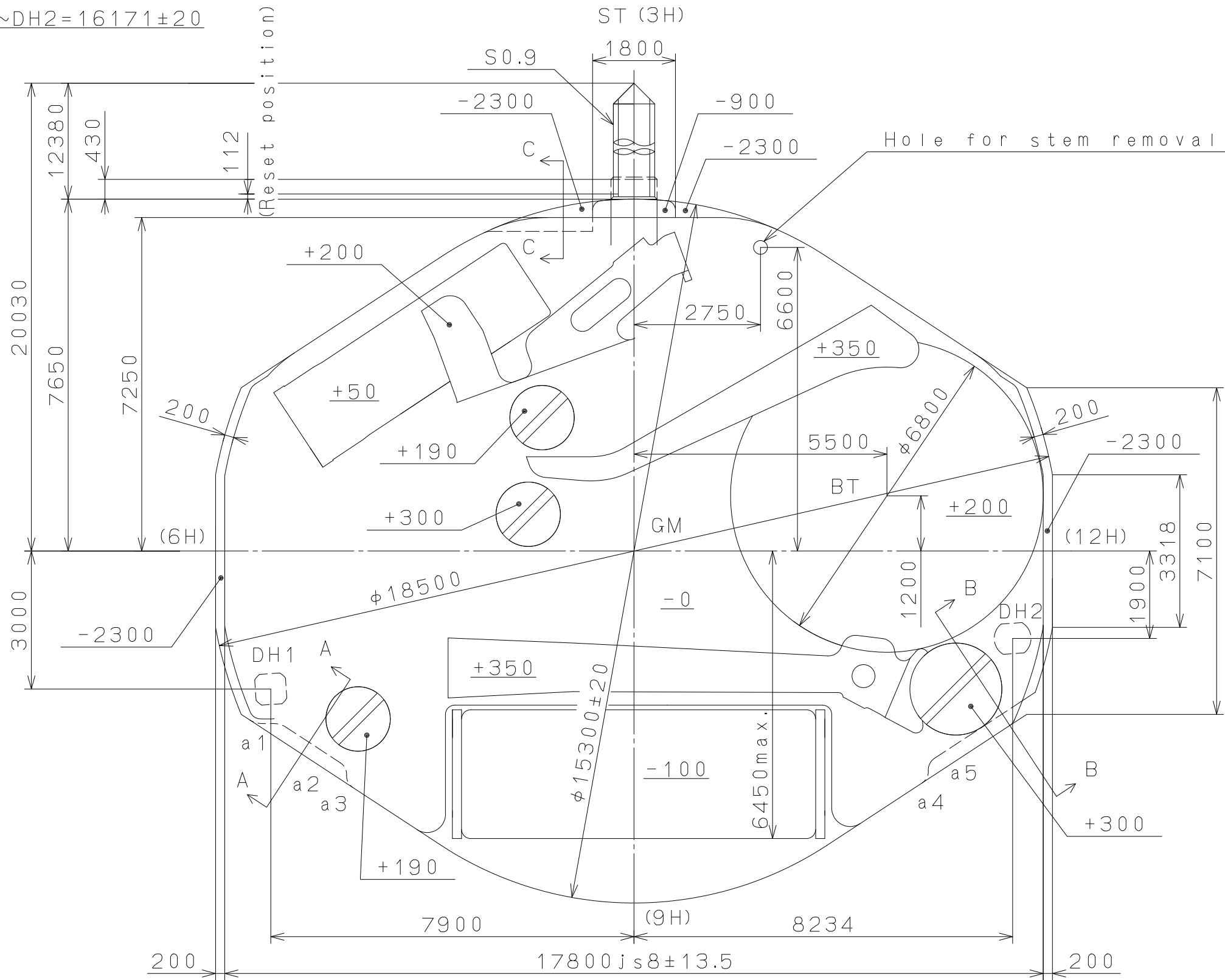
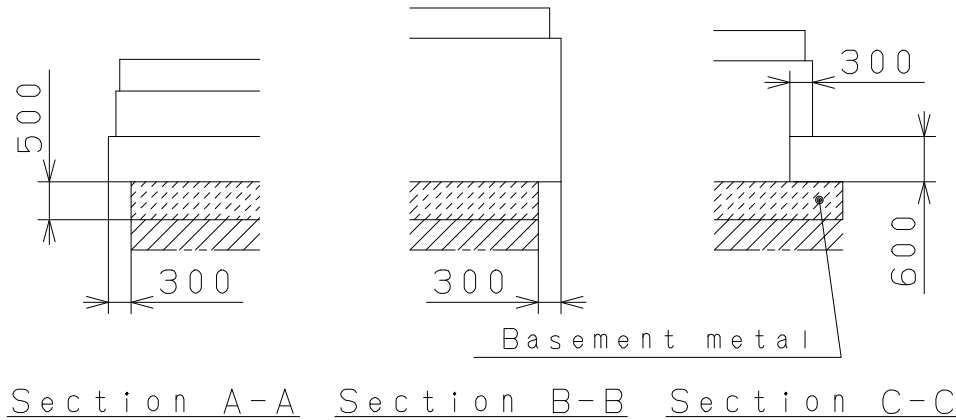

△5			Quantity		Cal.NO.:
△4			Unit	1/1000mm	2033
△3			Scale	10:1	Parts No.:
△2			Date		
△1			Drawn		
Mark	Date	Description	Appr.	Checked	T. Hiruta
Alterations				Approved	Name:
					Frame for Case
Material				Drawing No.: 2033C001	
Heat Treatment				General Tolerances	
Hardness				Dimensions	
Plating				Angles	

**MIYOTA**

CITIZEN WATCH CO., LTD. TOKYO, JAPAN